



Changes for the Better

FX3U SERIES PROGRAMMABLE CONTROLLERS

HARDWARE MANUAL

Manual Number	JY997D18801
Revision	G
Date	November 2008



This manual describes the part names, dimensions, mounting, cabling and specifications for the product. This manual is extracted from FX3U Series User's Manual - Hardware Edition. Refer to FX3U Series User's Manual - Hardware Edition for more details. Before use, read this manual and manuals of relevant products fully to acquire proficiency in the handling and operating the product. Make sure to learn all the product information, safety information, and precautions.

And, store this manual in a safe place so that you can take it out and read it whenever necessary. Always forward it to the end user.

Registration

The company name and the product name to be described in this manual are the registered trademarks or trademarks of each company.

Effective Nov. 2008

Specifications are subject to change without notice.

© 2005 Mitsubishi Electric Corporation

Safety Precaution (Read these precautions before use.)

This manual classifies the safety precautions into two categories:

DANGER and **CAUTION**.

DANGER	Indicates that incorrect handling may cause hazardous conditions, resulting in death or severe injury.
CAUTION	Indicates that incorrect handling may cause hazardous conditions, resulting in medium or slight personal injury or physical damage.

Depending on the circumstances, procedures indicated by **CAUTION** may also cause severe injury.

It is important to follow all precautions for personal safety.

STARTUP AND MAINTENANCE PRECAUTIONS **DANGER**

- Do not touch any terminal while the PLC's power is on. Doing so may cause electric shock or malfunctions.
- Before cleaning or retightening terminals externally cut off all phases of the power supply. Failure to do so may cause electric shock.
- Make sure to connect the battery for memory backup correctly. Do not charge, disassemble, heat, short-circuit, or expose the battery to fire. Doing so may rupture or ignite it.
- Before modifying or disrupting the program in operation or running the PLC, carefully read through this manual and the associated manuals and ensure the safety of the operation. An operation error may damage the machinery or cause accidents.

STARTUP AND MAINTENANCE PRECAUTIONS **CAUTION**

- Turn off the power to the PLC before attaching or detaching the memory cassette. If the memory cassette is attached or detached while the PLC's power is on, the data in the memory may be destroyed, or the memory cassette may be damaged.
- Do not disassemble or modify the PLC. Doing so may cause fire, equipment failures, or malfunctions. For repair, contact your local Mitsubishi Electric distributor.
- Turn off the power to the PLC before connecting or disconnecting any extension cable. Failure to do so may cause equipment failures or malfunctions.
- Turn off the power to the PLC before attaching or detaching the following devices. Failure to do so may cause equipment failures or malfunctions.
 - Display module, peripheral devices, expansion boards, and special adapters
 - Connector conversion adapter, extension blocks, and FX Series terminal blocks
 - Battery and memory cassette

DISPOSAL PRECAUTIONS **CAUTION**

- Please contact a certified electronic waste disposal company for the environmentally safe recycling and disposal of your device.

TRANSPORT AND STORAGE PRECAUTIONS **CAUTION**

- Before transporting the PLC, turn on the power to the PLC to check that the BATT LED is off. If the PLC is transported with the BATT LED on or the battery exhausted, the battery-backed data may be unstable during transportation.
- The PLC is a precision instrument. During transportation, avoid impacts larger than those specified in Section 2.1. Failure to do so may cause failures in the PLC. After transportation, verify the operations of the PLC.

Marine standard

Please consult with Mitsubishi Electric for the information on marine standard practices and the corresponding types of equipment.

Certification of UL, cUL standards

FX3U main units and input/output extension units/blocks supporting UL, cUL standards are as follows:

UL, cUL file number :E95239
Models : MELSEC FX3U series manufactured
 FX3U-★MR/ES(-A) FX3U-★MT/ES(-A)
 FX3U-★MT/ESS
 Where ★★ indicates:16,32,48,64,80,128
 FX3U-★MR/DS FX3U-★MT/DS
 FX3U-★MT/DSS
 Where ★★ indicates:16,32,48,64,80
 FX3U-232ADP FX3U-485ADP
 FX3U-4AD-ADP FX3U-4DA-ADP
 FX3U-4AD-PT-ADP FX3U-4AD-TC-ADP
 FX3U-4HSX-ADP FX3U-2HSY-ADP

Models : MELSEC FX2N series manufactured
 FX2N-★ER-ES/UL FX2N-★ET-ESS/UL
 Where ★★ indicates:32,48
 FX2N-48ER-DS FX2N-48ET-DSS
 FX2N-48ER-UA1/UL
 FX2N-8ER-ES/UL FX2N-8EX-ES/UL
 FX2N-8EYR-ES/UL FX2N-8EYT-ESS/UL
 FX2N-8EX-UA1/UL
 FX2N-16EX-ES/UL FX2N-16EYR-ES/UL
 FX2N-16EYT-ESS/UL

Compliance with EC directive(CE Marking)

This document does not guarantee that a mechanical system including this product will comply with the following standards. Compliance to EMC directive and LVD directive of the entire mechanical system should be checked by the user / manufacturer. For more details please contact the local Mitsubishi Electric sales site.

Requirement for Compliance with EMC directive

The following products have shown compliance through direct testing (of the identified standards below) and design analysis (through the creation of a technical construction file) to the European Directive for Electromagnetic Compatibility (89/336/EEC) when used as directed by the appropriate documentation.

Type : Programmable Controller (Open Type Equipment)
Models : MELSEC FX3U series manufactured
 from May 1st, 2005 FX3U-★MR/ES(-A)
 Where ★★ indicates:16,32,48,64,80
 FX3U-4HSX-ADP FX3U-2HSY-ADP
 FX3U-FLROM-16 FX3U-FLROM-64L
 FX3U-7DM
 from June 1st, 2005 FX3U-232ADP FX3U-485ADP
 FX3U-4AD-ADP FX3U-4DA-ADP
 FX3U-4AD-PT-ADP FX3U-4AD-TC-ADP
 FX3U-232-BD FX3U-422-BD
 FX3U-485-BD FX3U-USB-BD
 FX3U-FLROM-64 FX3U-CNV-BD
 from November 1st, 2005 FX3U-★MT/ES(-A)
 FX3U-★MT/ESS
 Where ★★ indicates:16,32,48,64,80

from February 1st, 2006 FX3U-128MR/ES(-A) FX3U-128MT/ES(-A)
 FX3U-128MT/ESS
 FX3U-★MR/DS FX3U-★MT/DS
 FX3U-★MT/DSS
 Where ★★ indicates:16,32,48,64,80

Standard	Remark
EN61131-2:2003 Programmable controllers - Equipment requirements and tests	Compliance with all relevant aspects of the standard. <ul style="list-style-type: none"> Radiated Emissions Mains Terminal Voltage Emissions RF immunity Fast Transients ESD <ul style="list-style-type: none"> Surge Voltage drops and interruptions Conducted Power magnetic fields

Models : MELSEC FX2N series manufactured
 from July 1st, 1997 FX2N-★ER-ES/UL FX2N-★ET-ESS/UL
 Where ★★ indicates:32,48
 FX2N-16EX-ES/UL FX2N-16EYR-ES/UL
 FX2N-16EYT-ESS/UL
 from April 1st, 1998 FX2N-48ER-DS FX2N-48ET-DSS
 from August 1st, 1998 FX2N-48ER-UA1/UL
 from August 1st, 2005 FX2N-8ER-ES/UL FX2N-8EX-ES/UL
 FX2N-8EYR-ES/UL FX2N-8EYT-ESS/UL

For the products above, PLCs manufactured before March 31st, 2002 are compliant with EN50081-2 (EN61000-6-4) and EN50082-2
 from April 1st, 2002 to April 30th, 2006 are compliant with EN50081-2 (EN61000-6-4) and EN61131-2:1994+A11:1996+A12:2000
 after May 1st, 2006 are compliant with EN61131-2:2003

Standard	Remark
EN61000-6-4:2001 - Generic emission standard Industrial environment EN50081-2:1993 Electromagnetic compatibility	Compliance with all relevant aspects of the standard. <ul style="list-style-type: none"> Radiated Emissions Mains Terminal Voltage Emissions
EN50082-2:1995 Electromagnetic compatibility - Generic immunity standard Industrial environment	Compliance with all relevant aspects of the standard. <ul style="list-style-type: none"> RF immunity Fast Transients ESD Conducted Power magnetic fields
EN61131-2:1994 /A11:1996 /A12:2000 Programmable controllers - Equipment requirements and tests	Compliance with all relevant aspects of the standard. <ul style="list-style-type: none"> RF Immunity Fast Transients ESD Damped oscillatory wave
EN61131-2:2003 Programmable controllers - Equipment requirements and tests	Compliance with all relevant aspects of the standard. <ul style="list-style-type: none"> Radiated Emissions Mains Terminal Voltage Emissions RF immunity Fast Transients ESD <ul style="list-style-type: none"> Surge Voltage drops and interruptions Conducted Power magnetic fields

Requirement for Compliance with LVD directive

The following products have shown compliance through direct testing (of the identified standards below) and design analysis (through the creation of a technical construction file) to the European Directive for Low Voltage (73/23/EEC) when used as directed by the appropriate documentation.

Type : Programmable Controller (Open Type Equipment)
Models : MELSEC FX3U series manufactured

- from May 1st, 2005 FX3U-★*MR/ES(-A)
Where ★★ indicates:16,32,48,64,80
- from November 1st, 2005 FX3U-★*MT/ES(-A)
FX3U-★*MT/ESS
Where ★★ indicates:16,32,48,64,80
- from February 1st, 2006 FX3U-128MR/ES(-A)
FX3U-128MT/ES(-A)
FX3U-128MT/ESS
FX3U-★*MR/DS
Where ★★ indicates:16,32,48,64,80

Standard	Remark
EN61131-2:2003 Programmable controllers - Equipment requirements and tests	The equipment has been assessed as a component for fitting in a suitable enclosure which meets the requirements of EN61131-2:2003

Models :MELSEC FX2N series manufactured

- from July 1st, 1997 FX2N-★*ER-ES/UL FX2N-★*ET-ESS/UL
Where ★★ indicates:32,48
FX2N-16EYR-ES/UL
- from April 1st, 1998 FX2N-48ER-DS
- from August 1st, 1998 FX2N-48ER-UA1/UL
- from August 1st, 2005 FX2N-8ER-ES/UL FX2N-8EYR-ES/UL

For the products above, PLCs manufactured before March 31st, 2002 are compliant with IEC1010-1 from April 1st, 2002 to April 30th, 2006 are compliant with EN61131-2:1994+A11:1996+A12:2000 after May 1st, 2006 are compliant with EN61131-2:2003

Standard	Remark
IEC1010-1:1990 /A1:1992 Safety requirements for electrical equipment for measurement, control, and laboratory use - General requirements	The equipment has been assessed as a component for fitting in a suitable enclosure which meets the requirements of IEC 1010-1:1990+A1:1992
EN61131-2:1994 :2003 /A12:2000 /A11:1996 Programmable controllers - Equipment requirements and tests	The equipment has been assessed as a component for fitting in a suitable enclosure which meets the requirements of EN61131-2:1994+A11:1996+A12:2000, :2003

Caution for compliance with EC Directive

Installation in Enclosure

Programmable logic controllers are open-type devices that must be installed and used within conductive control boxes. Please use the FX3U Series programmable logic controllers while installed in conductive shielded control boxes. Please secure the control box lid to the control box (for conduction). Installation within a control box greatly affects the safety of the system and aids in shielding noise from the programmable logic controller.

Caution for Analog Products in use

The analog special adapters have been found to be compliant to the European standards in the aforesaid manual and directive. However, for the very best performance from what are in fact delicate measuring and controlled output device Mitsubishi Electric would like to make the following points;

As analog devices are sensitive by nature, their use should be considered carefully. For users of proprietary cables (integral with sensors or actuators), these users should follow those manufacturers installation requirements. Mitsubishi Electric recommend that shielded cables should be used. If NO other EMC protection is provided, then users may experience temporary induced errors not exceeding +10%/-10% in very heavy industrial areas.

However, Mitsubishi Electric suggest that if adequate EMC precautions are followed with general good EMC practice for the users complete control system, users should expect normal errors as specified in this manual.

- Sensitive analog cable should not be laid in the same trunking or cable conduit as high voltage cabling. Where possible users should run analog cables separately.
- Good cable shielding should be used. When terminating the shield at Earth - ensure that no earth loops are accidentally created.
- When reading analog values, EMC induced errors can be smoothed out by averaging the readings. This can be achieved either through functions on the analog special adapter/block or through a users program in the FX3U Series PLC main unit.

Associated manuals

FX3U Series PLC (main unit) comes with this document (hardware manual).

For a detailed explanation of the FX3U Series hardware and information on instructions for PLC programming and special extension unit/block, refer to the relevant documents.

Manual name	Manual No.	Description
FX3U Series User's Manual - Hardware Edition	JY997D16501 MODEL CODE: 09R516	Explains FX3U Series PLC specification details for I/O, wiring, installation, and maintenance.
FX3U/FX3UC Series Programming Manual - Basic & Applied Instruction Edition	JY997D16601 MODEL CODE: 09R517	Describes PLC programming for basic/ applied instructions STL/ SFC programming and devices.
FX Series User's Manual - Data Communication Edition	JY997D16901 MODEL CODE: 09R715	Explains N:N link, parallel link, computer link, no protocol communication by RS instructions/FX2N-232IF.
FX3U / FX3UC Series User's Manual - Analog Control Edition	JY997D16701 MODEL CODE: 09R619	Describes specifications for analog control and programming methods for FX3U / FX3UC Series PLC.
FX3U / FX3UC Series User's Manual - Positioning Control Edition	JY997D16801 MODEL CODE: 09R620	Explains the specifications for positioning control of FX3U / FX3UC Series and programming procedures

How to obtain manuals

For the necessary product manuals or documents, consult with the Mitsubishi Electric dealer from where you purchase your product.

Incorporated Items

Check if the following product and items are included in the package:

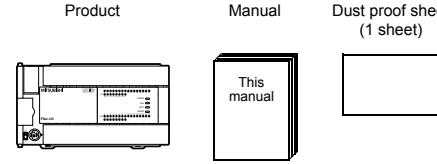

1. Outline

1.1 Part names

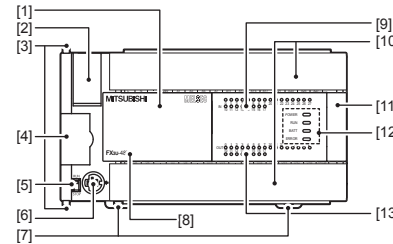

No.	Name		
[1]	Top cover		
[2]	Battery cover		
[3]	Special adapter connecting hooks (2 places)		
[4]	Expansion board dummy cover		
[5]	RUN/STOP switch		
[6]	Peripheral device connecting connector		
[7]	DIN rail mounting hooks		
[8]	Model name (abbreviation)		
[9]	Input display LEDs (Red)		
[10]	Terminal block covers		
[11]	Extension device connecting connector cover		
[12]	Operation status display LEDs		
	POWER	Green	On while power is on the PLC.
	RUN	Green	On while the PLC is running.
	BATT	Red	Lights when the battery voltage drops.
	ERROR	Red	Flashing when a program error occurs.
Red		Lights when a CPU error occurs.	
[13]	Output display LEDs (Red)		

With terminal cover open

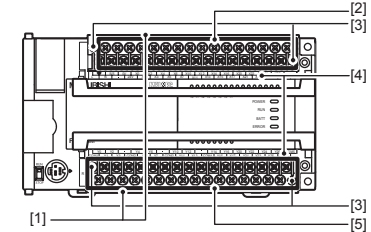

No.	Name
[1]	Protective terminal covers (FX3U-□□□□-A is excluded)
[2]	Power supply, Input (X) terminals
[3]	Terminal block mounting screws (FX3U-16M□ terminal block cannot be installed/removed)
[4]	Terminal names
[5]	Output (Y) terminals

1.2 External dimensions and weight

2-φ4.5-diam mounting holes (FX3U-16M□, FX3U-32M□)
 4-φ4.5-diam mounting holes (FX3U-48M□, FX3U-64M□, FX3U-80M□, FX3U-128M□)
 FX3U-16M□ and FX3U-32M□ do not have the (*)-marked mounting holes.

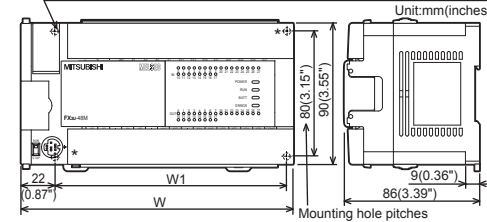

Model name	W: mm (inches)	W1: mm (inches) Direct mounting hole pitches	MASS (Weight): kg (lbs)
FX3U-16M□	130 (5.12")	103 (4.06")	0.6 (1.32lbs)
FX3U-32M□	150 (5.91")	123 (4.85")	0.65 (1.43lbs)
FX3U-48M□	182 (7.17")	155 (6.11")	0.85 (1.87lbs)
FX3U-64M□	220 (8.67")	193 (7.6")	1.00 (2.2lbs)
FX3U-80M□	285 (11.23")	258 (10.16")	1.20 (2.64lbs)
FX3U-128M□*1	350 (13.78")	323 (12.72")	1.80 (3.96lbs)

*1 FX3U-128M□ does not have DC power supply.

Installation

- 35-mm-wide DIN rail or Direct (screw) mounting (M4)

2. Installation (general specifications)

As for installation of the input/output extension blocks, special adapters and expansion boards, refer to FX3U Series User's Manual - Hardware Edition.

INSTALLATION PRECAUTIONS 

- Use the product within the generic environment specifications described in section 2.1 of this manual. Never use the product in areas with excessive dust, oily smoke, conductive dusts, corrosive gas (salt air, Cl₂, H₂S, SO₂ or NO₂), flammable gas, vibration or impacts, or exposed to high temperature, condensation, or rain and wind. If the product is used in such conditions, electric shock, fire, malfunctions, deterioration or damage may occur.
- Do not touch the conductive parts of the product directly to avoid failure or malfunctions.
- Install the product securely using a DIN rail or mounting screws.
- Install the product on a flat surface. If the mounting surface is rough, undue force will be applied to the PC board, thereby causing nonconformities.
- When drilling screw holes or wiring, make sure cutting or wire debris does not enter the ventilation slits. Failure to do so may cause fire, equipment failures or malfunctions.
- Be sure to remove the dust proof sheet from the PLC's ventilation port when installation work is completed. Failure to do so may cause fire, equipment failures or malfunctions.
- Connect the extension cables, peripheral device cables, input/output cables and battery connecting cable securely to their designated connectors. Unsecured connection may cause malfunctions.
- Turn off the power before attaching or detaching the following devices. Failure to do so may cause device failures or malfunctions.
 - Peripheral devices, display modules, expansion boards and special adapters
 - Extension units/blocks and the FX Series terminal block
 - Battery and memory cassette

Notes

- When a dust proof sheet is supplied with an extension unit/block, keep the sheet applied to the ventilation slits during installation and wiring work.
- To prevent temperature rise, do not install the PLC on a floor, a ceiling or a vertical surface. Install it horizontally on a wall as shown in section 2.2.
- Keep a space of 50 mm (1.97") or more between the unit main body and another device or structure (part A). Install the unit as far away as possible from high-voltage lines, high-voltage devices and power equipment.

WIRING PRECAUTIONS 

- Cut off all phases of the power supply externally before installation or wiring work in order to avoid damage to the product or electric shock.

2.1 Generic specifications [Main unit]

Item	Specification
Ambient temperature	0 to 55°C (32 to 131°F) when operating and -25 to 75°C (-13 to 167°F) when stored

Item	Specification					
Ambient humidity	5 to 95%RH (no condensation) when operating					
Vibration resistance	When installed on DIN rail	Fre- quency (Hz)	10 to 57	-	Sweep Count for X, Y, Z: 10 times (80 min in each direction)	
		Accele- ration (m/s ²)	57 to 150	4.9		-
	When installed directly	Fre- quency (Hz)	10 to 57	-		0.075
		Accele- ration (m/s ²)	57 to 150	9.8		-
Shock resistance	147 m/s ² Acceleration, Action time: 11ms, 3 times by half-sine pulse in each direction X, Y, and Z					
Noise resistance	By noise simulator at noise voltage of 1,000 Vp-p, noise width of 1 μs, rise time of 1 ns and period of 30 to 100 Hz					
Dielectric withstand voltage*1	1.5kV AC for one minute	Between each terminals*1 and ground terminal				
	500V AC for one minute					
Insulation resistance*1	5MΩ or more by 500V DC megger					
Grounding	Class D grounding (grounding resistance: 100 Ω or less) <Common grounding with a heavy electrical system is not allowed.>*2					
Working atmosphere	Free from corrosive or flammable gas and excessive conductive dusts					
Working altitude	<2000m ³					

*1

Terminal	Dielectric strength	Insulation resistance
Between power supply terminal (AC power) and ground terminal	1.5 kV AC for one minute	5MΩ or more by 500V DC megger
Between power supply terminal (DC power) and ground terminal	500V AC for one minute	
Between input terminal (24V DC) and ground terminal	500V AC for one minute	
Between output terminal (relay) and ground terminal	1.5 kV AC for one minute	
Between output terminal (transistor) and ground terminal	500V AC for one minute	

For dielectric with stand voltage test and insulation resistance test of each product, refer to the following manual. → Refer to FX3U Series User's Manual - Hardware Edition.

*2 For common grounding, refer to section 3.3.
 *3 The PLC cannot be used at a pressure higher than the atmospheric pressure to avoid damage.

2.2 Installation location

Install the PLC in an environment conforming to the generic specifications (section 2.1), installation precautions and notes.

For more details, refer to FX3U Series User's Manual - Hardware Edition.

Installation location in enclosure

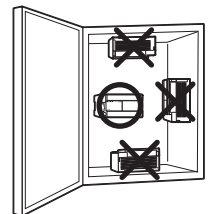

Space in enclosure

Extension devices can be connected on the left and right sides of the main unit of the PLC. If you intend to add extension devices in the future, keep necessary spaces on the left and right sides.

Configuration without extension cable

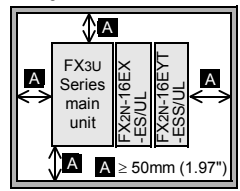

Configuration in 2 stages with extension cable

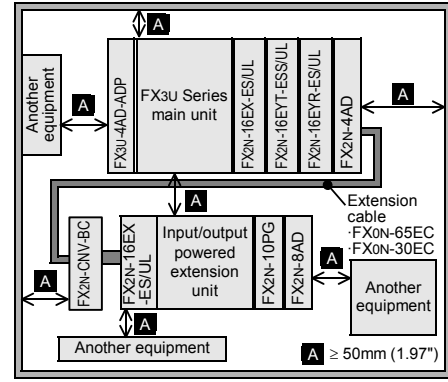

2.2.1 Affixing The Dust Proof Sheet

The dust proof sheet should be affixed to the ventilation port before beginning the installation and wiring work.

→ For the affixing procedure, refer to the instructions on the dust proof sheet.

Be sure to remove the dust proof sheet when the installation and wiring work is completed.

2.3 Procedures for installing to and detaching from DIN rail

The main unit can be installed on a DIN46277 rail [35 mm (1.38") wide].

2.3.1 Installation

- 1) Connect the expansion boards and special adapters to the main unit.
- 2) Push out all DIN rail mounting hooks (below fig.A)

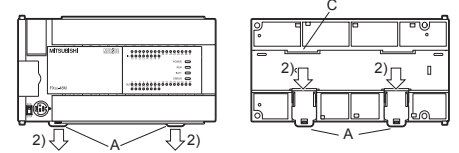

- 3) Fit the upper edge of the DIN rail mounting groove (right fig.C) onto the DIN rail.

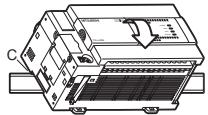

- 4) Lock the DIN rail mounting hooks (below fig.D) while pressing the PLC against the DIN rail.

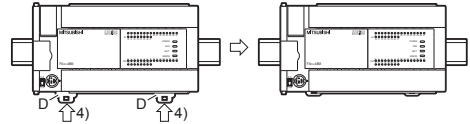

2.4 Procedures for installing directly (with M4 screws)

The product can be installed directly on the panel (with screws).

2.4.1 Mounting hole pitches

Refer to the External Dimensions (section 1.2) for the product's mounting hole pitch information. As for the details of the mounting hole pitches for extension unit/block and special adapters, refer to the following manual.

→ Refer to FX3U Series User's Manual - Hardware Edition.

2.4.2 Installation

- 1) Make mounting holes in the mounting surface referring to the external dimensions diagram.
- 2) Fit the main unit (A in the right figure) based on the holes, and secure it with M4 screws (B in the right figure). The mounting hole pitches and number of screws depend on the product. Refer to the external dimensions diagram.

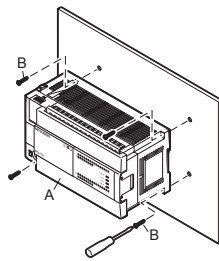

3. Power supply/input/output specifications and examples of external wiring

As for the details of the power supply wiring and input/output wiring, refer to FX3U Series User's Manual - Hardware Edition.

DESIGN PRECAUTIONS **DANGER**

- Make sure to have the following safety circuits outside of the PLC to ensure safe system operation even during external power supply problems or PLC failure. Otherwise, malfunctions may cause serious accidents.
 - Most importantly, have the following: an emergency stop circuit, a protection circuit, an interlock circuit for opposite movements (such as normal vs. reverse rotation), and an interlock circuit (to prevent damage to the equipment at the upper and lower positioning limits).
 - Note that when the PLC CPU detects an error, such as a watchdog timer error, during self-diagnosis, all outputs are turned off. Also, when an error that cannot be detected by the PLC CPU occurs in an input/output control block, output control may be disabled. External circuits and mechanisms should be designed to ensure safe machinery operation in such a case.
 - Note that when an error occurs in a relay, triac or transistor output device, the output could be held either on or off. For output signals that may lead to serious accidents, external circuits and mechanisms should be designed to ensure safe machinery operation in such a case.

DESIGN PRECAUTIONS **CAUTION**

- Do not bundle the control line together with or lay it close to the main circuit or power line. As a guideline, lay the control line at least 100mm (3.94") or more away from the main circuit or power line. Noise may cause malfunctions.
- Install module so that excessive force will not be applied to the built-in programming connectors, power connectors or I/O connectors. Failure to do so may result in wire damage/breakage or PLC failure.

Notes

- Simultaneously turn on and off the power supplies of the main unit and extension devices.
- Even if the power supply causes an instantaneous power failure for less than 10 ms, the PLC can continue to operate.
- If a long-time power failure or an abnormal voltage drop occurs, the PLC stops, and output is turned off. When the power supply is restored, it will automatically restart (when the RUN input is on).

WIRING PRECAUTIONS **DANGER**

- Cut off all phases of the power supply externally before installation or wiring work in order to avoid damage to the product or electric shock.

WIRING PRECAUTIONS **CAUTION**

- Connect the AC power supply to the dedicated terminals specified in this manual. If an AC power supply is connected to a DC input/output terminal or DC power supply terminal, the PLC will burn out.
- Do not wire vacant terminals externally. Doing so may damage the product.
- Use class D grounding (grounding resistance of 100Ω or less) with a wire of 2mm² or thicker on the grounding terminal of the FX3U Series main unit. However, do not connect the ground terminal at the same point as a heavy electrical system.
- When drilling screw holes or wiring, make sure cutting or wire debris does not enter the ventilation slits. Failure to do so may cause fire, equipment failures or malfunctions.

Notes

- Input/output wiring 50 to 100 m (164'1" to 328'1") long will cause almost no problems of noise, but, generally, the wiring length should be less than 20 m (65'7") to ensure the safety.
- Extension cables are easily affected by noise. Lay the cables at a distance of at least 30 to 50 mm (1.19" to 1.97") away from the PLC output and other power lines.

3.1 Wiring

3.1.1 Cable end treatment and tightening torque

For the terminals of FX3U series PLC, M3 screws are used. The electric wire ends should be treated as shown below. Tighten the screws to a torque of 0.5 N·m to 0.8 N·m.

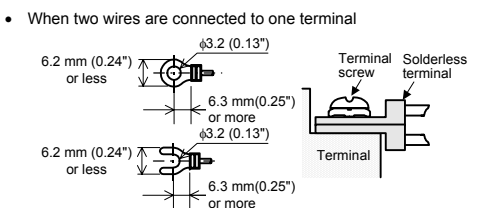
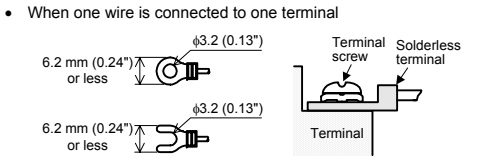

3.1.2 Removal and installation of quick-release terminal block

Removal Unscrew the terminal block mounting screw [both right and left screws] evenly, and remove the terminal block.

Installation Place the terminal block in the specified position, and tighten the terminal block mounting screw evenly [both right and left screws]. Tightening torque 0.4 to 0.5 N·m
* Pay attention so that the center of the terminal block is not lifted.

3.2 Power supply specifications and example of external wiring

→ Refer to FX3U Series User's Manual - Hardware Edition.

3.2.1 Power supply specifications

The specifications for the power supply of the main unit are shown in the following table.

Item	Specification		
	AC power type	DC power type ^{*7}	
Supply voltage	100 - 240V AC	24 V DC	
Allowable supply voltage range	85 - 264V AC	16.8-28.8V DC ^{*6}	
Rated frequency	50/60Hz	-	
Allowable instantaneous power failure time	Operation can be continued upon occurrence of instantaneous power failure for 10 ms or less. ^{*4}	Operation can be continued upon occurrence of instantaneous power failure for 5 ms or less.	
Power fuse	FX3U-16M□ to 32M□	250V AC 3.15A	
	FX3U-48M□ to 128M□ ^{*5}	250V AC 5A	
Rush current	30 A max. 5 ms or less/100 V AC	35 A max. 0.5 ms or less/24 V DC	
	65 A max. 5 ms or less/200 V AC		
Power consumption ^{*1}	FX3U-16M□	30W	25W
	FX3U-32M□	35W	30W
	FX3U-48M□	40W	35W
	FX3U-64M□	45W	40W
	FX3U-80M□	50W	45W
24V DC service power supply ^{*2}	FX3U-16M□ to 32M□	400 mA or less	-
	FX3U-48M□ to 128M□ ^{*5}	600 mA or less	-
5V DC built-in power supply ^{*3}		500 mA or less	

- ^{*1} Does not include the power consumption of extension units / special extension units, and of the extension blocks / special extension blocks connected to those units. For the power (current) consumed by the extension units/blocks for input/output, refer to FX3U Series User's Manual - Hardware Edition. For the power consumed by the special extension units/blocks, refer to the appropriate manual.
- ^{*2} When input/output extension blocks are connected, the 24V DC service power supply is consumed by the blocks, and the current value to be used by the main unit is reduced.
- ^{*3} Cannot be used to supply power to an external destination. The power is supplied to input/output extension blocks, special extension blocks, special adapters and expansion boards.
- ^{*4} When the supply voltage is 200 V AC, the time can be changed to 10 to 100 ms by editing the user program.
- ^{*5} FX3U-128M□ does not have DC power supply.
- ^{*6} When supply voltage is DC 16.8-19.2V, the connectable extension equipment decreases. The following manual shows further information.
→ Refer to FX3U Series User's Manual - Hardware Edition.

^{*7} When attaching high-speed input/output special adapter (FX3U-4HSX-ADP, FX3U-2HSY-ADP) and special function block (FX0N-3A, FX2N-2AD, FX2N-2DA), the number of connectable modules to the main unit is limited, due to the current consumption (internal 24V DC) at startup. The following manual shows further information.

→ Refer to FX3U Series User's Manual - Hardware Edition.

3.2.2 Example of external wiring (AC power type)

100 to 240V AC power is supplied to the main unit. For the details of wiring work, refer to section 3.1.

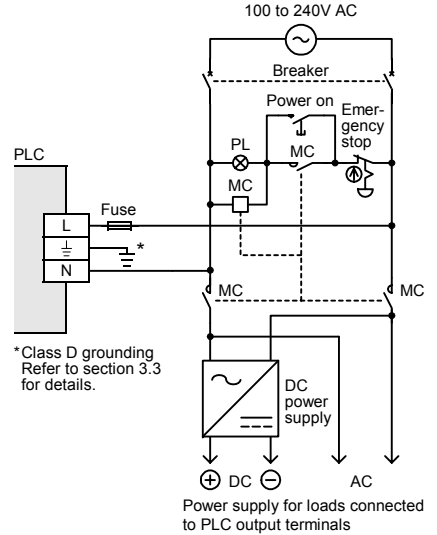

3.2.3 Example of external wiring (DC power type)

24V DC power is supplied to the main unit. For the details of wiring work, refer to section 3.1.

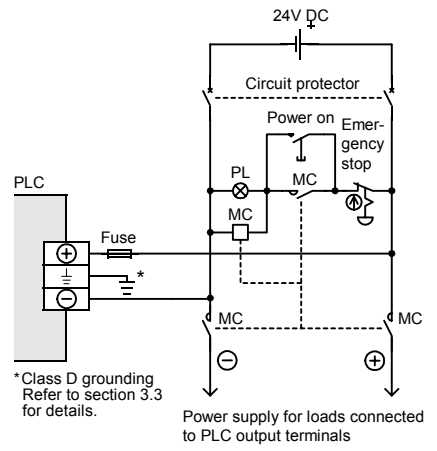

3.3 Grounding

Ground the PLC as stated below.

- Perform class D grounding. (Grounding resistance: 100 Ω or less)
- Ground the PLC independently if possible. If it cannot be grounded independently, ground it jointly as shown below.

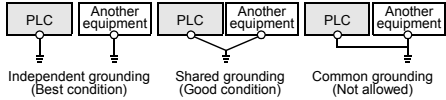

- Use ground wires thicker than AWG14 (2 mm²).
- Position the grounding point as close to the PLC as possible to decrease the length of the ground wire.

3.4 Input specifications and external wiring

→ Refer to FX3u Series User's Manual - Hardware Edition.

3.4.1 Input specifications

Item	Specification
Number of input points	FX3u-16M□ 8 points
	FX3u-32M□ 16 points
	FX3u-48M□ 24 points
	FX3u-64M□ 32 points
	FX3u-80M□ 40 points
	FX3u-128M□*1 64 points
Input connecting type	Removable terminal block (M3 screw)*2
Input form	Sink/source
Input signal voltage	24V DC +10%, -10%*3
Input impedance	X000 to X005 3.9kΩ
	X006, X007 3.3kΩ
Input signal current	X010 or more 4.3kΩ (Does not apply to FX3u-16M□.)
	X000 to X005 6mA/24V DC
	X006, X007 7mA/24V DC
ON input sensitivity current	X010 or more 5mA/24V DC (Does not apply to FX3u-16M□.)
	X000 to X005 3.5 mA or more
	X006, X007 4.5 mA or more
	X010 or more 3.5 mA or more (Does not apply to FX3u-16M□.)
OFF input sensitivity current	1.5 mA or less
Input response time	Approx. 10 ms

3.4.4 Instructions for connecting input devices

- 1) In the case of no-voltage contact: The input current of this PLC is 5 to 7 mA/24V DC. Use input devices applicable to this minute current. If no-voltage contacts (switches) for large current are used, contact failure may occur.

<Example> Products of OMRON

Type	Model name	Type	Model name
Microswitch	Models Z, V and D2RV	Operation switch	Model A3P
Proximity switch	Model TL	Photoelectric switch	Model E3S

- 2) In the case of input device with built-in series diode: The voltage drop of the series diode should be approx. 4 V or less. When lead switches with a series LED are used, up to two switches can be connected in series. Also make sure that the input current is over the input-sensing level while the switches are ON.

• Sink input

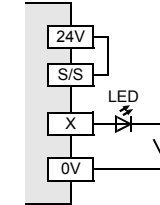

• Source input

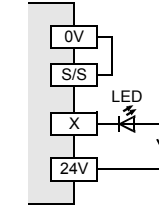

- 3) In the case of input device with built-in parallel resistance: Use a device having a parallel resistance, Rp, of 15 kΩ or more. When the resistance is less than 15 kΩ, connect a bleeder resistance, Rb, obtained from the formula as shown in the following figure.

$$R_b \leq \frac{4R_p}{15-R_p} (k\Omega)$$

• Sink input

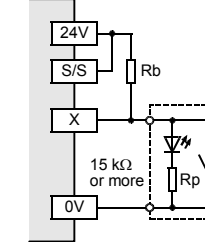

• Source input

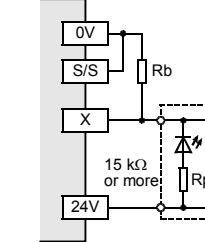

Item	Specification
Input signal form	<ul style="list-style-type: none"> • Sink input: No-voltage contact input, NPN open collector transistor • Source input: No-voltage contact input, PNP open collector transistor
Input circuit insulation	Photocoupler insulation
Input operation display	LED on panel lights when photocoupler is driven.

- *1 FX3u-128M□ does not have DC power supply.
- *2 FX3u-16M□ terminal block cannot be installed/removed
- *3 For DC power type, the power range applies to "3.2.1 term Power supply specifications."

3.4.2 Examples of input wiring[AC power type]

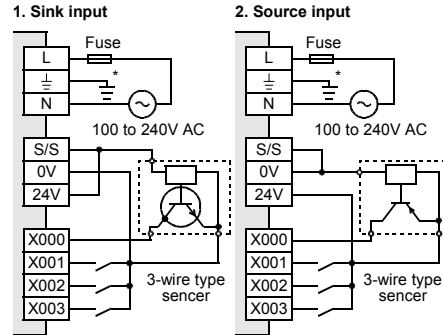

*Class D grounding Refer to section 3.3 for details.

3.4.3 Examples of input wiring[DC power type]

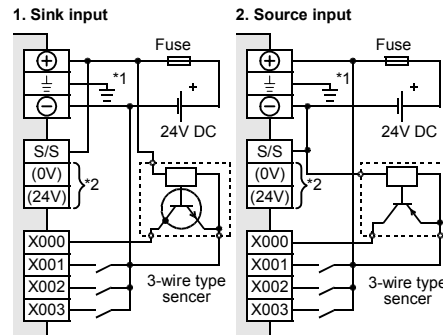

- *1 Class D grounding Refer to section 3.3 for details.
- *2 Do not connect the (0V) and (24V) terminal with others, since they are not available.

- 4) In the case of 2-wire proximity switch: Use a two-wire proximity switch whose leakage current, I_l, is 1.5 mA or less when the switch is off. When the current is 1.5 mA or more, connect a bleeder resistance, Rb, obtained from formula as shown in the following figure.

$$R_b \leq \frac{6}{I_l - 1.5} (k\Omega)$$

• Sink input

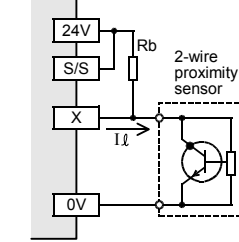

• Source input

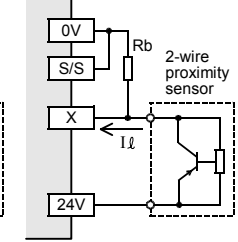

3.5 Relay output specifications and example of external wiring

→ Refer to FX3u Series User's Manual - Hardware Edition.

3.5.1 Relay output specifications

Item	Specification	
Number of output points	FX3u-16MR/□ 8 points	
	FX3u-32MR/□ 16 points	
	FX3u-48MR/□ 24 points	
	FX3u-64MR/□ 32 points	
	FX3u-80MR/□ 40 points	
	FX3u-128MRVES*1 64 points	
Output connecting type	Removable terminal block (M3 screw)*2	
Output form	Relay	
External power supply	30V DC or less 240V AC or less ("250V AC or less" if not a CE, UL, cUL compliant item)	
Max. load	Resistance load 2 A /point	
	Inductive load 80VA	
Min. load	5V DC, 2 mA (reference value)	
Open circuit leakage current	-	
Response time	OFF→ON	Approx. 10 ms
	ON→OFF	Approx. 10 ms
Circuit insulation	Mechanical insulation	
Display of output operation	LED lights when power is applied to relay coil.	

- *1 FX3u-128M□ does not have DC power supply.
- *2 FX3u-16M□ terminal block cannot be installed/removed

Number of output points per common terminal

- On FX3U-16M□, one common terminal is used for 1 output point.
- On models other than FX3U-16M□, 1 common terminal is used for 4 or 8 output points.

3.5.2 Life of relay output contact

The product life of relay contacts considerably varies depending on the load type used. Take care that loads generating reverse electromotive force or rush current may cause poor contact or deposition of contacts which may lead to considerable reduction of the contact product life.

- 1) Inductive load
Inductive loads generate large reverse electromotive force between contacts at shutdown which may cause arcing. At a fixed current consumption, as the power factor (phase between current and voltage) gets smaller, the arc energy gets larger. The standard life of the contact used for inductive loads, such as contactors and solenoid valves, is 500 thousand operations at 20VA.

The following table shows the approximate life of the relay based on the results of our operation life test.

Test condition: 1 sec.ON / 1 sec.OFF.

Load capacity		Contact life
20VA	0.2A/100V AC	3 million times
	0.1A/200V AC	
35VA	0.35A/100V AC	1 million times
	0.17A/200V AC	
80VA	0.8A/100V AC	2 hundred thousand times
	0.4A/200V AC	

The product life of relay contacts becomes considerably shorter than the above conditions when the rush overcurrent is shut down.

→ For countermeasures while using inductive loads, refer to Subsection 3.5.4.

- Some types of inductive loads generate rush current 5 to 15 times the stationary current at activation. Make sure that the rush current does not exceed the current corresponding to the maximum specified resistance load.

- 2) Lamp load
Lamp loads generally generate rush current 10 to 15 times the stationary current. Make sure that the rush current does not exceed the current corresponding to the maximum specified resistance load.
- 3) Capacitive load
Capacitive loads can generate rush current 20 to 40 times the stationary current. Make sure that the rush current does not exceed the current corresponding to the maximum specified resistance load. Capacitive loads such as capacitors may be present in electronic circuit loads including inverters.

→ For the maximum specified resistance load, refer to Subsection 3.5.1.

3.5.3 Example of relay output wiring

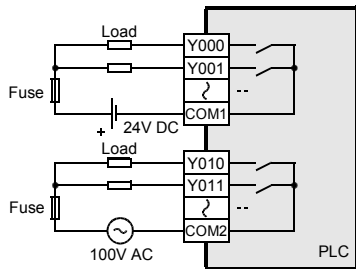

3.5.4 Cautions in external wiring

Protection circuit for load short-circuiting

When a load connected to the output terminal short-circuits, the printed circuit board may be burnt out. Fit a protective fuse on the output circuit.

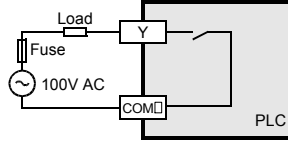

Protection circuit of contact when inductive load is used

An internal protection circuit for the relays is not provided for the relay output circuit in this product. It is recommended to use inductive loads with built-in protection circuits. When using loads without built-in protection circuits, insert an external contact protection circuit, etc. to reduce noise and extend the product life.

- 1) DC circuit
Connect a diode in parallel with the load. Use a diode (for commutation) having the following specifications.

Item	Standard
Reverse voltage	5 to 10 times the load voltage
Forward current	Load current or more

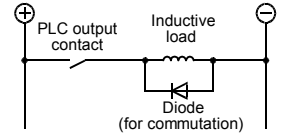

- 2) AC circuit
Connect the surge absorber (combined CR components such as a surge killer and spark killer, etc.) parallel to the load. Select the rated voltage of the surge absorber suitable to the output used. Refer to the table below for other specifications.

Item	Standard
Electrostatic capacity	Approx. 0.1μF
Resistance value	Approx. 100 to 200Ω

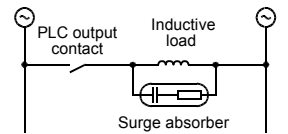

Reference

Manufacturer	Model name
Okaya Electric Industries Co., Ltd.	CR-10201
Rubycon Corporation	250MCRA104100M B0325

Interlock

Loads, such as contactors for normal and reverse rotations, that must not be turned on simultaneously should have an interlock in the PLC program and an external interlock as shown below.

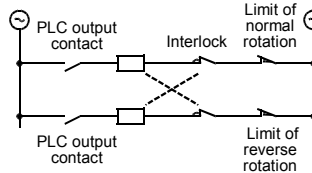

Common mode

Use output contacts (*) of the PLC in the common mode.

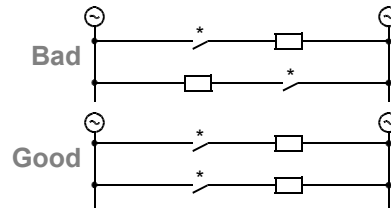

3.6 Transistor output specifications and example of external wiring

→ Refer to FX3U Series User's Manual - Hardware Edition. Transistor output specifications

Item	Specification	
Number of output points	FX3U-16MT/□	8 points
	FX3U-32MT/□	16 points
	FX3U-48MT/□	24 points
	FX3U-64MT/□	32 points
	FX3U-80MT/□	40 points
	FX3U-128MT/ES(S)*1	64 points
Output connecting type	Removable terminal block (M3 screw)*2	
Output form	FX3U-□□MT/□S(-A)	Transistor(Sink)
	FX3U-□□MT/□SS	Transistor(Source)
External power supply	5 to 30V DC	
Max. load	Resistance load	The total load current of resistance loads per common terminal should be the following value or less. - 1 output point/common terminal: 0.5 A - 4 output point/common terminal: 0.8 A - 8 output point/common terminal: 1.6 A
	Inductive load	12 W/24V DC
Min. load	-	
Open circuit leakage current	0.1 mA or less/30V DC	
ON voltage	1.5 V or less	

Item		Specification	
Response time	OFF→ON	Y000 to Y002	5 μs or less/10 mA or more (5 to 24V DC)
		Y003 or more	0.2 ms or less/200 mA or more (at 24V DC)
	ON→OFF	Y000 to Y002	5 μs or less/10 mA or more (5 to 24V DC)
		Y003 or more	0.2 ms or less/200 mA or more (at 24V DC)
Circuit insulation		Photocoupler insulation	
Display of output operation		LED on panel lights when photocoupler is driven.	

*1 FX3U-128M□ does not have DC power supply.
*2 FX3U-16M□ terminal block cannot be installed/removed

Number of output points per common terminal

- On FX3U-16M□, one common terminal is used for 1 output point.
- On models other than FX3U-16M□, 1 common terminal is used for 4 or 8 output points.

3.6.1 External Wiring of Transistor Output

1. External Wiring of Sink Output Type

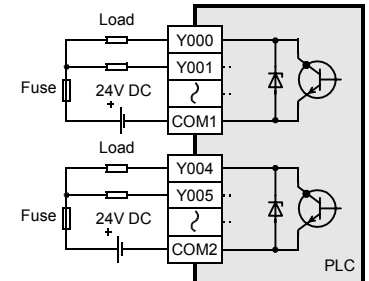

2. External Wiring of Source Output Type

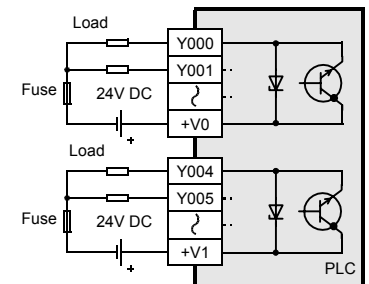

3.6.2 Cautions in external wiring

Protection circuit for load short-circuits

A short-circuit at a load connected to an output terminal could cause burnout at the output element or the PCB. To prevent this, a protection fuse should be inserted at the output. Use a load power supply capacity that is at least 2 times larger than the total rated fuse capacity.

1. External Wiring of Sink Output Type

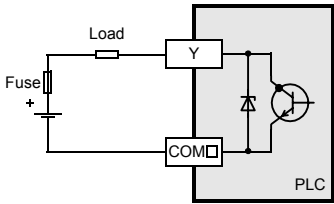

2. External Wiring of Source Output Type

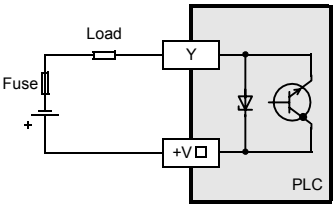

Contact protection circuit for inductive loads

When an inductive load is connected, connect a diode (for commutation) in parallel with the load as necessary. The diode (for commutation) must comply with the following specifications.

Table with 2 columns: Item, Guide. Rows: Reverse voltage (5 to 10 times of the load voltage), Forward current (Load current or more).

1. External Wiring of Sink Output Type

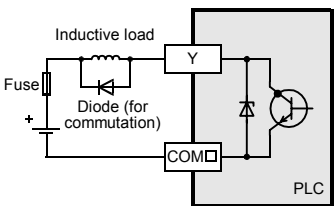

2. External Wiring of Source Output Type

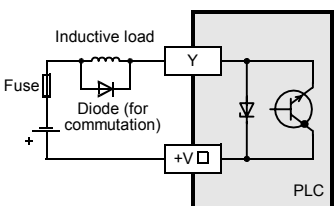

Interlock

Loads, such as contactors for normal and reverse rotations, that must not be turned on simultaneously should have an interlock in the PLC program and an external interlock as shown below.

1. External Wiring of Sink Output Type

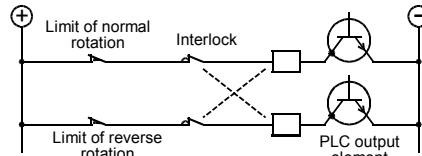

2. External Wiring of Source Output Type

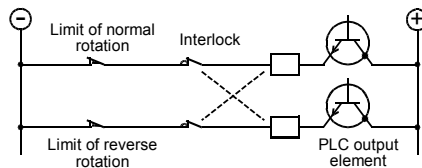

4. Terminal block layouts

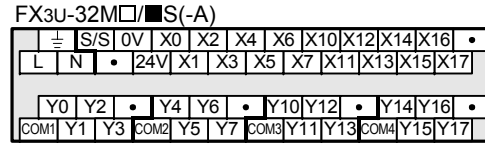
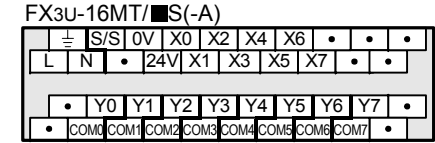
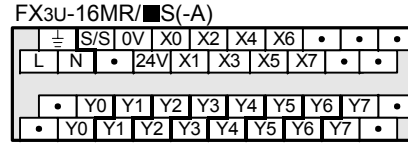

-DC power type DC power terminal block differs from AC power terminal block as follows.

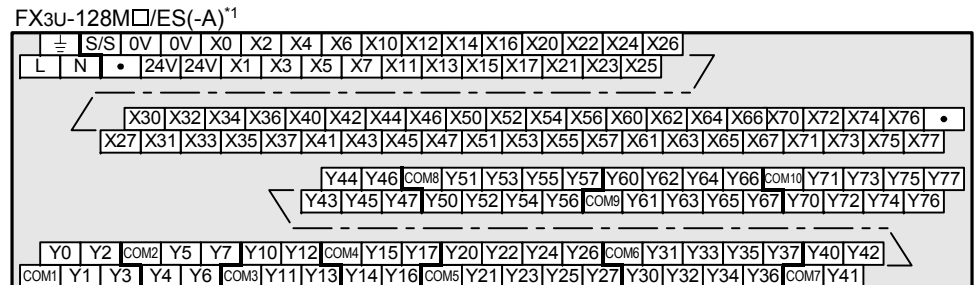
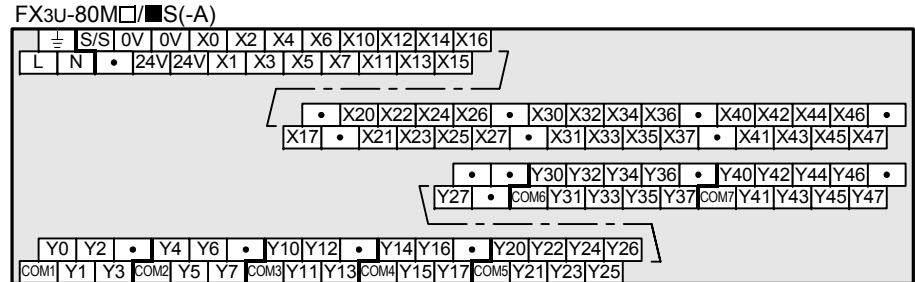
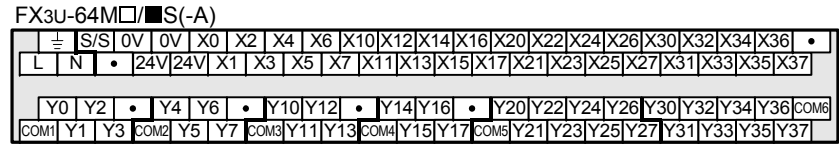
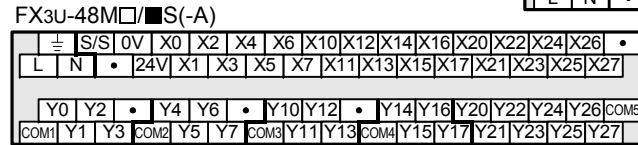
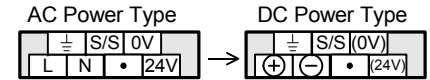

*1 FX3U-128 M□/ES(-A) does not have DC power supply.

FX3U-16MT/□SS

±	S/S	0V	X0	X2	X4	X6	•	•	•
L	N	•	24V	X1	X3	X5	X7	•	•
•	Y0	Y1	Y2	Y3	Y4	Y5	Y6	Y7	•
•	+V0	+V1	+V2	+V3	+V4	+V5	+V6	+V7	•

FX3U-32MT/□SS

±	S/S	0V	X0	X2	X4	X6	X10	X12	X14	X16	•
L	N	•	24V	X1	X3	X5	X7	X11	X13	X15	X17
Y0	Y2	•	Y4	Y6	•	Y10	Y12	•	Y14	Y16	•
+V0	Y1	Y3	+V1	Y5	Y7	+V2	Y11	Y13	+V3	Y15	Y17

FX3U-48MT/□SS

±	S/S	0V	X0	X2	X4	X6	X10	X12	X14	X16	X20	X22	X24	X26	•
L	N	•	24V	X1	X3	X5	X7	X11	X13	X15	X17	X21	X23	X25	X27
Y0	Y2	•	Y4	Y6	•	Y10	Y12	•	Y14	Y16	Y20	Y22	Y24	Y26	+V4
+V0	Y1	Y3	+V1	Y5	Y7	+V2	Y11	Y13	+V3	Y15	Y17	Y21	Y23	Y25	Y27

FX3U-64MT/□SS

±	S/S	0V	0V	X0	X2	X4	X6	X10	X12	X14	X16	X20	X22	X24	X26	X30	X32	X34	X36	•
L	N	•	24V	24V	X1	X3	X5	X7	X11	X13	X15	X17	X21	X23	X25	X27	X31	X33	X35	X37
Y0	Y2	•	Y4	Y6	•	Y10	Y12	•	Y14	Y16	•	Y20	Y22	Y24	Y26	Y30	Y32	Y34	Y36	+V5
+V0	Y1	Y3	+V1	Y5	Y7	+V2	Y11	Y13	+V3	Y15	Y17	+V4	Y21	Y23	Y25	Y27	Y31	Y33	Y35	Y37

FX3U-80MT/□SS

±	S/S	0V	0V	X0	X2	X4	X6	X10	X12	X14	X16																	
L	N	•	24V	24V	X1	X3	X5	X7	X11	X13	X15																	
												•	X20	X22	X24	X26	•	X30	X32	X34	X36	•	X40	X42	X44	X46	•	
												X17	•	X21	X23	X25	X27	•	X31	X33	X35	X37	•	X41	X43	X45	X47	
												•	•	Y30	Y32	Y34	Y36	•	Y40	Y42	Y44	Y46	•					
												Y27	•	+V5	Y31	Y33	Y35	Y37	+V6	Y41	Y43	Y45	Y47					
Y0	Y2	•	Y4	Y6	•	Y10	Y12	•	Y14	Y16	•	Y20	Y22	Y24	Y26													
+V0	Y1	Y3	+V1	Y5	Y7	+V2	Y11	Y13	+V3	Y15	Y17	+V4	Y21	Y23	Y25													

FX3U-128MT/ESS*2

±	S/S	0V	0V	X0	X2	X4	X6	X10	X12	X14	X16	X20	X22	X24	X26																						
L	N	•	24V	24V	X1	X3	X5	X7	X11	X13	X15	X17	X21	X23	X25																						
																X30	X32	X34	X36	X40	X42	X44	X46	X50	X52	X54	X56	X60	X62	X64	X66	X70	X72	X74	X76	•	
																X27	X31	X33	X35	X37	X41	X43	X45	X47	X51	X53	X55	X57	X61	X63	X65	X67	X71	X73	X75	X77	
																Y44	Y46	+V7	Y51	Y53	Y55	Y57	Y60	Y62	Y64	Y66	+V9	Y71	Y73	Y75	Y77						
																Y43	Y45	Y47	Y50	Y52	Y54	Y56	+V8	Y61	Y63	Y65	Y67	Y70	Y72	Y74	Y76						
Y0	Y2	+V1	Y5	Y7	Y10	Y12	+V3	Y15	Y17	Y20	Y22	Y24	Y26	+V5	Y31	Y33	Y35	Y37	Y40	Y42																	
+V0	Y1	Y3	Y4	Y6	+V2	Y11	Y13	Y14	Y16	+V4	Y21	Y23	Y25	Y27	Y30	Y32	Y34	Y36	+V6	Y41																	

*2 FX3U-128MT/ESS does not have DC power supply.

This manual confers no industrial property rights or any rights of any other kind, nor does it confer any patent licenses. Mitsubishi Electric Corporation cannot be held responsible for any problems involving industrial property rights which may occur as a result of using the contents noted in this manual.

Warranty
Mitsubishi will not be held liable for damage caused by factors found not to be the cause of Mitsubishi; opportunity loss or lost profits caused by faults in the Mitsubishi products; damage, secondary damage, accident compensation caused by special factors unpredictable by Mitsubishi; damages to products other than Mitsubishi products; and to other duties.

 For safe use
<ul style="list-style-type: none"> • This product has been manufactured as a general-purpose part for general industries, and has not been designed or manufactured to be incorporated in a device or system used in purposes related to human life. • Before using the product for special purposes such as nuclear power, electric power, aerospace, medicine or passenger movement vehicles, consult with Mitsubishi Electric. • This product has been manufactured under strict quality control. However when installing the product where major accidents or losses could occur if the product fails, install appropriate backup or failsafe functions in the system.